

Multi-Channel AI DashCam

Quick Start Manual V1.3

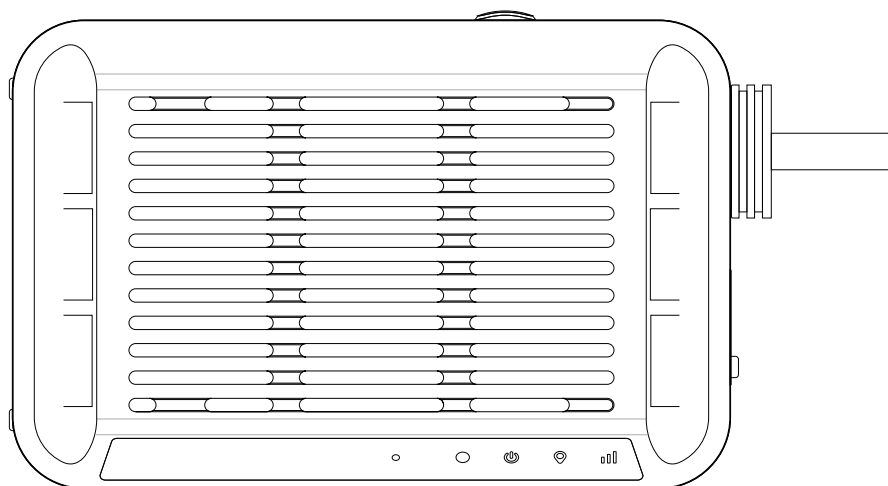

Before using this product, please read this manual carefully in order to use this product correctly. With the purpose of performance improvement, this manual is subject to changes without notice.

01 / Product Overview

1.1 Appearance Description

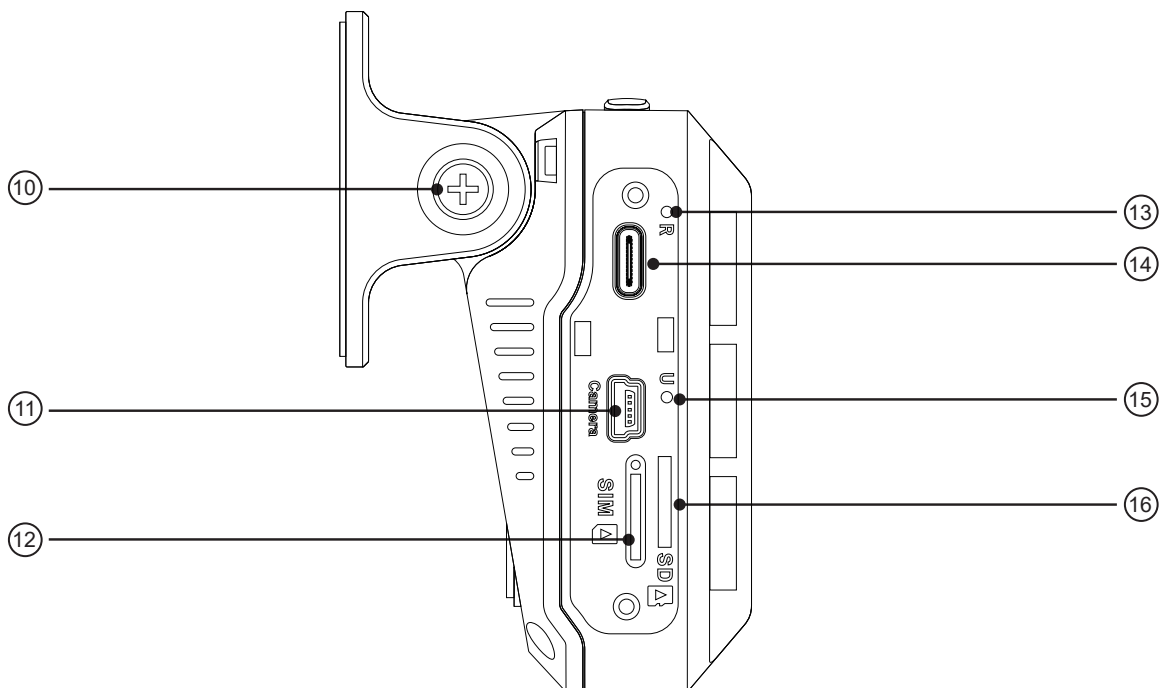
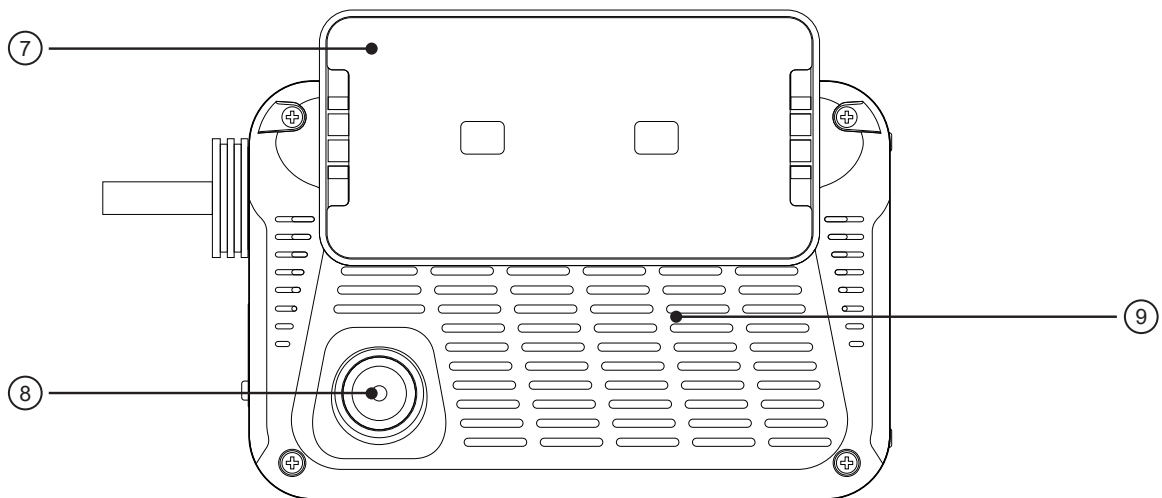
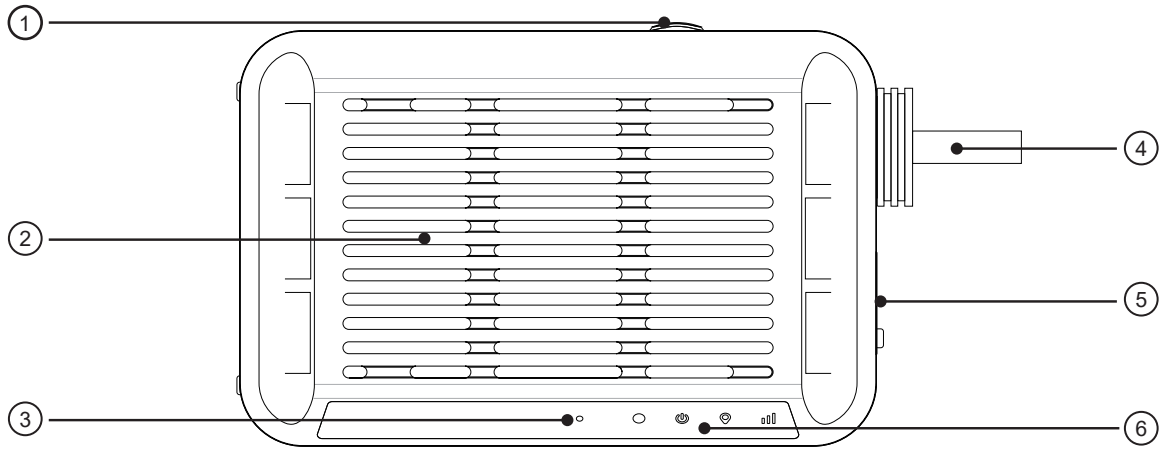

Item	Function	Item	Function
①	Function button	⑨	Speaker
②	Cooling window	⑩	Fastener screw
③	Microphone	⑪	External camera interface
④	Power cable	⑫	SIM card slot
⑤	Type-C (for function expansion)	⑬	Reset hole
⑥	LED indication	⑭	Type-C (for upgrade)
⑦	Mount base	⑮	Upgrade hole
⑧	Main camera	⑯	SD card slot

1.2 LED Indication

Red	Off	○○○○○	The device is shut down.
	Solid on	●●●●●	The device is ACC (ignition) on and records normally.
	Flash	●○●○●○	The device is ACC on but recording function is abnormal.
Green	Off	○○○○○	The device is shut down or in sleep mode.
	Solid on	●●●●●	The device is ACC on and pinpoints locations normally.
	Flash	●○●○●○	The device is ACC on but the positioning function is abnormal.
Blue	Off	○○○○○	The device is shut down or in sleep mode.
	Solid on	●●●●●	The device is ACC on and has normal network access.
	Flash	●○●○●○	The device is ACC on but fails to access the network.
	Slow flash	●○○○○●	The device has network access, but fails to connect with the platform.
White	Off	○○○○○	AI algorithm is not running.
	Solid on	●●●●●	AI Algorithm is in operation.
	Flash	●○●○●○	A DMS or ADAS event is triggered.

02 / Packing List

2.1 Standard

Item	Name	Qty
1	Device unit	1
2	Mount base	1
3	Card slot protective cover	1
4	Power cable	1
5	SOS button	1
6	T6 torx screwdriver	1
7	M2 screws	3

2.2 Optional

The device series requires a SIM card and a memory card to function its best. You can purchase the two accessories according to your specific needs, but the following requirements must be met:

- **Memory card**

1. The device supports one Micro SD card;
2. The card must be in FAT32 format with a capacity of 16GB to 256GB;
3. The card must be rated Class 10 or higher, or perform A1 or higher;
4. It is recommended to use a memory card from the original manufacturer of your device to ensure optimal compatibility and stability;
5. Insert the card by the direction shown in the figure to protect the card against damage;
6. Press the card inward to remove it. If you are removing the card in your car, use moderate force to ensure that the card is not ejected out to an inaccessible location;
7. Make sure the SIM card is not inserted into the memory card slot;
8. Memory cards are consumables, which means they have a tested lifespan. It is recommended that you test the card quarterly to ensure that it is reading and writing normally, and replace it periodically to protect your video files from loss;
9. It is recommended to use industrial grade memory cards if the device is used for a long period of time every day to avoid video recording exceptions caused by hot weather.

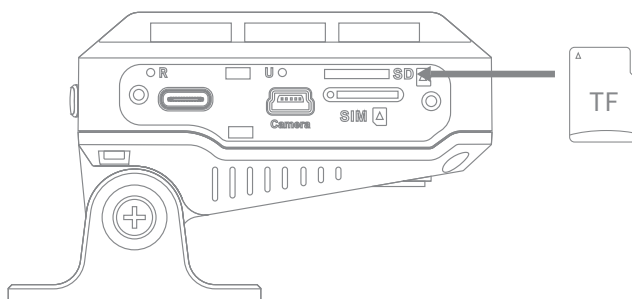

- **SIM card**

1. A Nano SIM card is required (refer to the following figure for card size);
2. Use the supplied card tray for the SIM card installation;
3. Attach or detach the SIM card (make sure the device is in the ACC OFF state) by the steps shown in Figure(2);
4. Make sure the SIM card is subscribed to a cellular data service;
5. Use the supplied ejector pin to remove the card tray and the SIM card;
6. It is recommended to use ceramic SIM cards if the device is used for a long period of time every day to avoid card deformation and communication failures caused by high temperature.

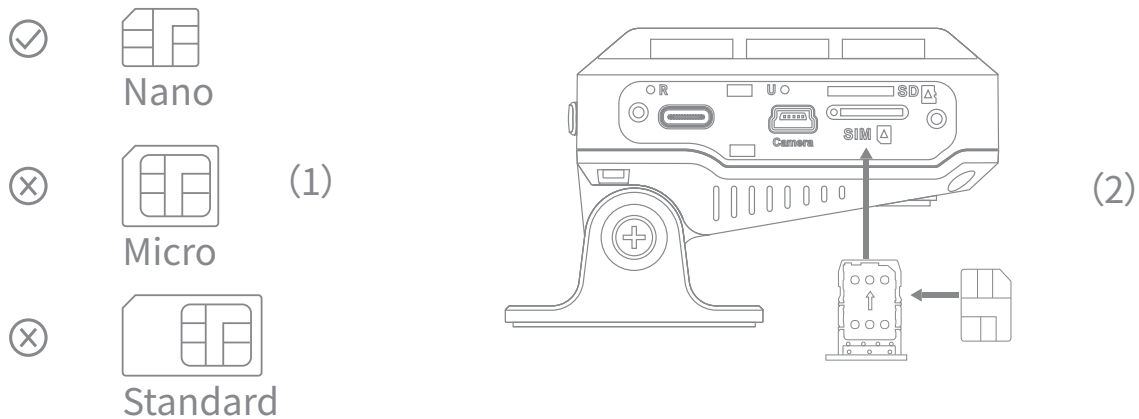

03 / Product Functions

The device, designed specifically for commercial vehicles, is a powerful remote video monitoring terminal that supports up to 3 cameras and incorporates advanced visual AI algorithms like ADAS and DMS. Its built-in antenna system simplifies wiring, delivering enhanced economy, convenience, visibility, and intelligence to fleet managers. The device keeps tabs on following distance, lane keeping, and driver alertness, ensuring that drivers and fleet managers receive instant in-cab alerts for potential hazards, making the road safer. It also has emergency alert features like a panic button and uploads relevant video clips to the cloud for storage.

A comprehensive management solution, the device is perfect for managing commercial fleets in public transportation, logistics, hazardous materials, and ride-sharing services.

3.1 Product Features

- **Video Recording**

The device supports up to 3 camera channels to provide a 360-degree live view of the vehicle's inside and surroundings. It also supports cloud storage of critical video footage for evidentiary support and after-the-fact driver coaching.

- **Visual AI Algorithms**

It utilizes visual AI algorithms - DMS (fatigue, phone use and distraction) and ADAS (following distance, near collision, and lane-keeping assistance) - to analyze the real-time road conditions and driver alertness, and can identify and alert the driver of potential risks, thus ensuring driving and driver safety. Furthermore, it is capable of more advanced features like facial recognition (Face ID) and seatbelt use detection, providing more comprehensive data on driver and their driving practices.

- **Multi-Source Positioning**

The device uses GPS and BDS to provide precise vehicle location and speed, so fleet managers can track their fleet in real time and check trip history of their fleets on a cloud-based platform like Tracksolid Pro, which can provide data-driven insight for route optimization.

- **4G Connectivity**

The device ensures high-speed and stable data transmission through 4G networks (with 2G fallback), enabling real-time video streaming via a cloud-based platform from anywhere at any time.

- **Remote Management**

The device allows fleet managers to remotely monitor and manage vehicles through an online platform, which allows fleet managers to access live video feed, monitor vehicle status, and immobilize the vehicle via an optional relay, improving management efficiency and preventing theft (and rapid recovery of stolen vehicles).

- **Event Alerts**

The device constantly monitors the vehicle. Once an event is detected such as overspeed, harsh braking, harsh acceleration, and SOS button activation, it will send an alert to the platform, record a related video footage, and/or emits an in-cab voice prompt to remind the driver.

- **Extension Interfaces**

The device is designed with multiple interfaces to support the connection of peripherals like fuel sensors and temperature sensors, providing a more comprehensive solution that meets the requirements of various commercial applications.

- **Built-in eMMC**

The device dashcam is equipped with a highly-reliable 128GB eMMC memory and also supports external memory card, providing user with multiple data storage methods and offering higher storage efficiency and reliability.

3.2 Configurations and Parameters

Parameter	Value	Parameter	Value
Core	Dual-core	NPU	1 Tops
RAM	256MB	No. of camera channels	Up to 3
Internal memory	eMMC 128G	GNSS	GPS, BDS, AGPS
External memory	TF card (up to 256GB*1)	G-sensor	6-axis
Cellular	4G LTE	Speaker	Built-in
Wireless network	WiFi 2.4G 802.11n	Microphone	Built-in
Function button	Built-in, Customizable features	Weight	283g
		Dimensions	118×77×31 (mm)
Frequency bands	2G Network GPRS/EDGE 900/1800 MHZ 3G Network WCDMA/HSDPA/HSUPA Band 1/5/8 4G Network FDD LTE Band 1/3/5/7/8/20/28A/28B TDD LTE Band 38/40		

3.3 Product Performance

Configuration	Parameter	Configuration	Parameter
Operating voltage	DC 9-30V	Undervoltage protection	9V, Customizable voltage threshold for shutdown.
Operating temperature	-20°C-70°C	Overvoltage protection	36V
Storage temperature	-30°C-85°C	Reversed connection protection	Support
ESD protection	Air ±14KV; Contact ±7KV	Flame retardant rating	UL94 V-0

04 / Product Installation

4.1 Note

- Use the supplied accessories for the installation;
- The power supply for the device is DC 9-30V. Please connect the positive and negative terminals of the power cable correctly to prevent any damage to the vehicle;
- When installation is complete, remove the protective film from the camera lens for optimal capture effect;
- Use a memory card and a SIM card recommended in this guide;
- Ask your dealer or a professional agency to perform the installation and testing as described in this guide.

4.2 Installation Preparation

- Check the package you received against the packing list and make sure everything is in good condition before installing;
- Prepare the installation tools (insulation tape, assembly and disassembly tool, etc.);
- Check if all original functions of the vehicle in which the device is to be installed are normal. If any exception is found, do not proceed with the installation;
- Take necessary cleaning and protection measures to the vehicle in advance.

4.3 Product Pre-installation

Before installation, it is recommended that you install all necessary accessories on the device, including:

- Insert an eligible memory card correctly into the device;
- Place an eligible SIM card in the card tray and insert it into the device;
- Select a proper install position and clean the position.

4.4 Product Wiring Diagram

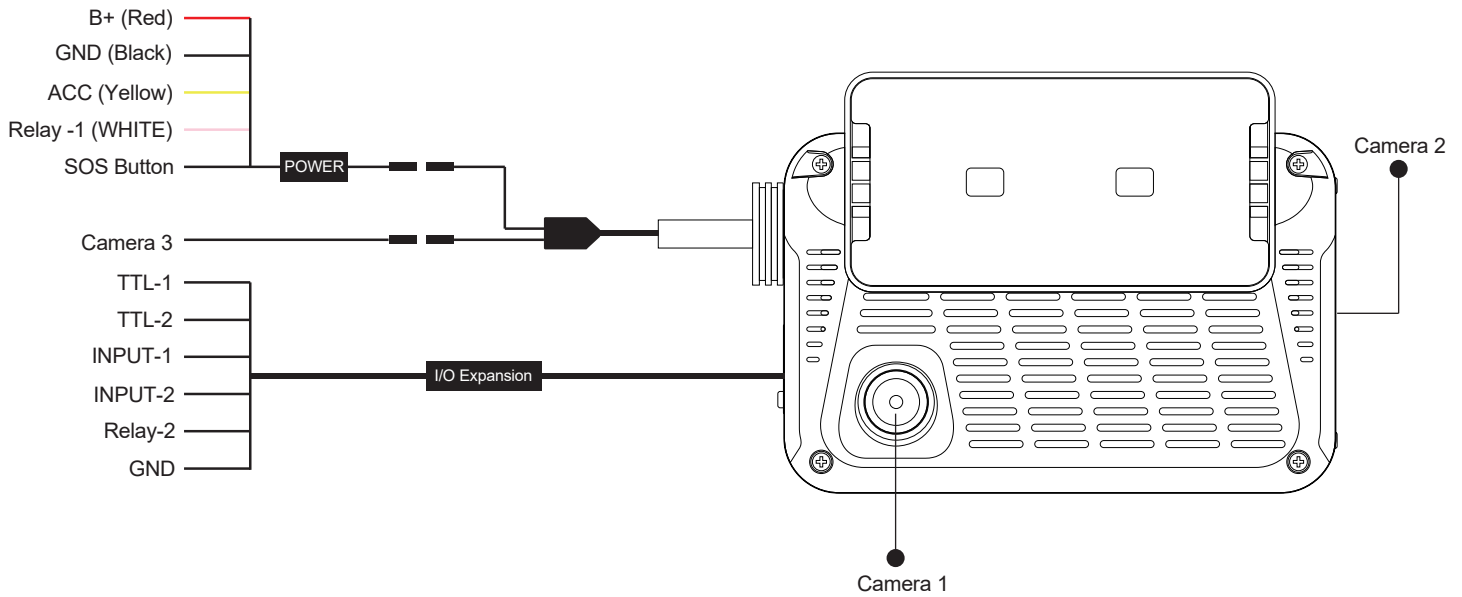

Installation description

1. The description of all harnesses is shown in the Figure above. Please check the procured accessories and connect and install them according to actual conditions.
2. When relevant I/O expansion function is not available, the I/O extension cable may not be installed in order to reduce the number of harnesses for installation.
3. A special extension cable may be added for the pull-out camera in order to perform remote installation.

4.5 Installation

It is recommended that the main unit of the device be installed at the bottom center of the vehicle's windshield. The entire installation consists of the installation of the body and the routing of the power cable.

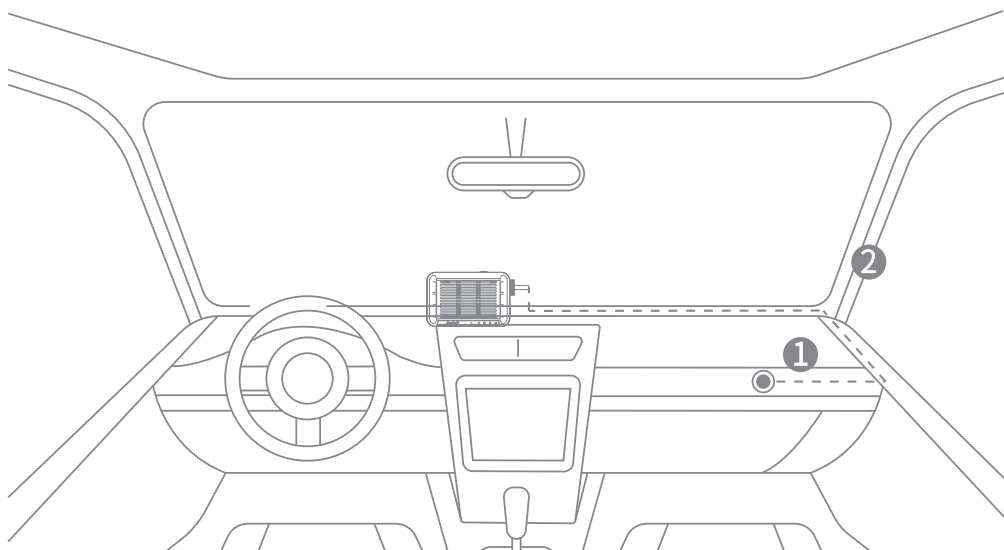

Step 1: Connect the power cable of the device with the B+, ACC, and GND wires from the vehicle fuse box. Refer to Figure ① for the location.

Step 2: Route the power cable along the edge of the dashboard to the bottom center of the front windshield. Refer to the dotted line in Figure ②.

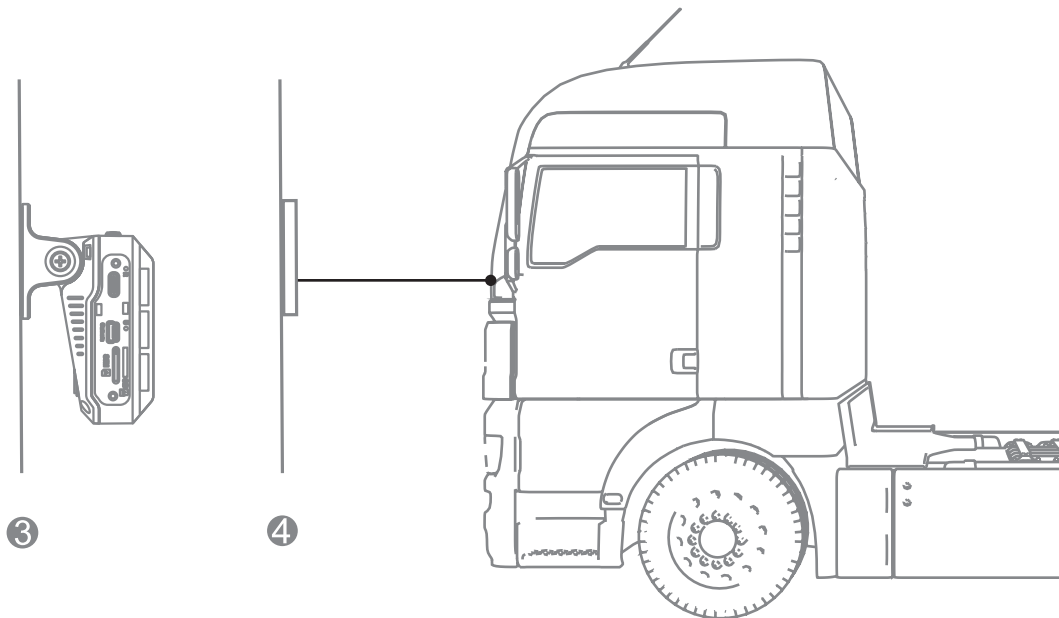

Step 3: Attach the mount base

Select a suitable position on the front windshield, with the area near the driver's side at the bottom center of the windshield being recommended.

Clean the mounting position to ensure there is no dust or smudges; Remove the protective film from the 3M double-sided adhesive tape on the mount base and attach the base to the mounting position, as shown in Figure ③.

After attaching the base, apply a moderate amount of force to enhance the contact and squeeze out the air to ensure that the mount base stays in place without falling.

Step 4: Mount the device on the base and adjust the road-facing camera so that it is facing forward horizontally, as shown in Figure ④. Tighten the adjustment screw of the base and connect the power cable to complete the installation.

4.6 Camera Installation

The device can simultaneously support connections for up to three cameras; among these, the front camera is the built-in main lens, while the other two cameras can be selected and installed according to your actual needs with installation positions chosen based on the specific application scenario.

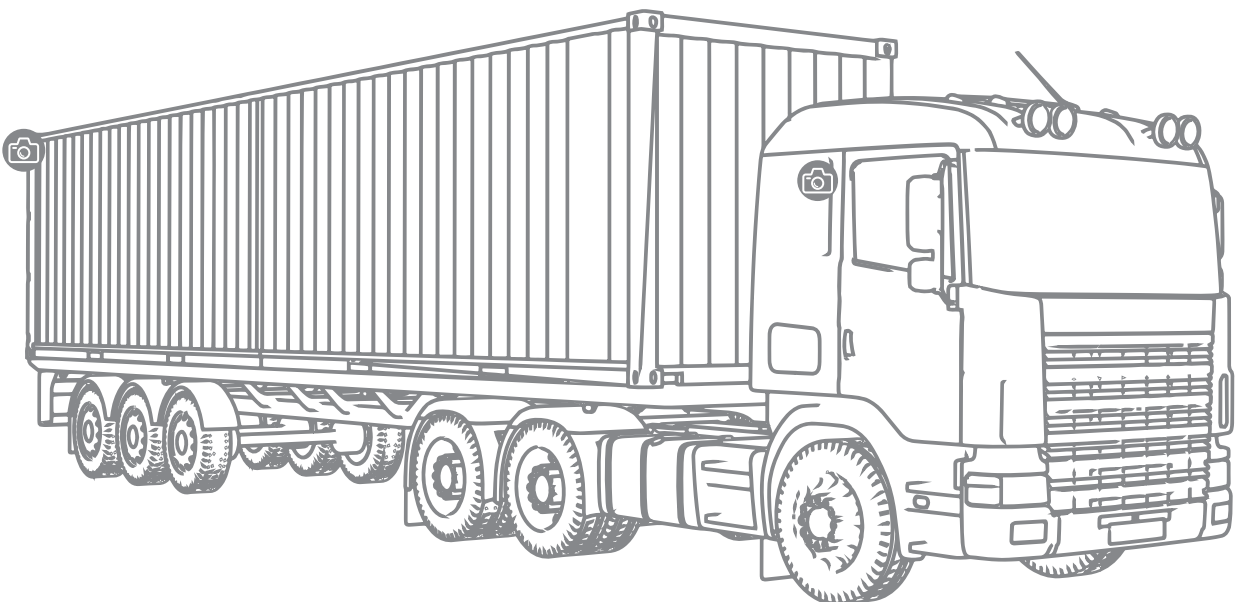

4.7 Installation of Other Accessories

1. SOS Button Installation

It is used to ask for help in emergency situations. Connect the SOS button to the corresponding wire of the device; remove the protective film of the 3M adhesive tape and attach it to a convenient location.

2. Relay Installation

For the installation of the relay, please refer to Section 4.4. You can remotely control the relay to immobilize a vehicle moving under 20km/h by cutting off the vehicle's power supply.

3. TTL Installation (Optional)

The TTL serial cable is used for connecting external devices. If you would like to expand the functionality of the device like fuel consumption or temperature monitoring, you can purchase one separately.

4.8 Device Testing

1. Check the power cable connection: Normally, when the vehicle is in the ACC ON state, the power indicator (red) of the device will light on; otherwise, the power indicator will be off.

2. Check the GNSS function of the device: Normally, when the vehicle's ignition is turned to the ON position, the GNSS indicator (green) will flash; you can drive your vehicle to an open area and wait for one minute, then the GNSS indicator will change to solid on.

3. Check the data communication function of the device: Normally, when the vehicle's ignition is turned to the ON position, the cellular indicator (blue) will flash; you can drive your vehicle to a place where the cellular signals are good, then the cellular indicator will change to solid on.

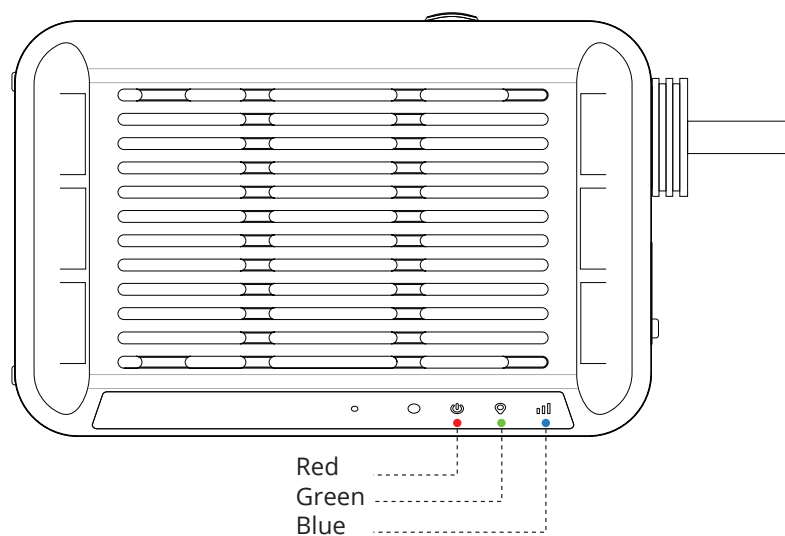

4. Check the cameras: Log in to the designated mobile app and go to the live video interface. If you can switch between cameras, then the cameras are working properly. You can manually adjust the capture angle of the cameras according to actual conditions.

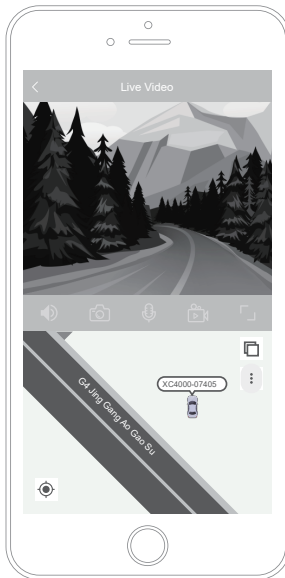

05 / Main Functions

5.1 Basic Operation

- **Startup**

When the B+, ACC and GND wires of the device are connected with the vehicle power correctly, the device will be started automatically without manual intervention.

- **Shutdown**

The device shuts down automatically if the power source to it is disconnected.

- **Sleep**

The device will disable its recording, GNSS, and other functions if it detects that the vehicle's ignition is turned to the OFF position. Then it will enter the sleep mode to save power.

5.2 Main Functions

- **Video recording**

When the vehicle's ignition is turned to the ON position, the device will start recording automatically. It will simultaneously record video, including audio, captured by the connected camera(s). This function can make use of loop recording to store video on the memory card, without human intervention.

- **Tracking**

When the vehicle's ignition is turned to the ON position, the device will automatically activate its GNSS module to fix positions. This function enables the device to track and acquire the geographic location of the vehicle, which is uploaded to the cloud server.

- **Event monitoring**

When in operation, the device can monitor the vehicle speed, gravity acceleration, driver and vehicle status, etc.; when an abnormal condition occurs, the device issues an alert to remind the driver and uploads the event with geographic location and image/video evidence to the platform.

- **Visual AI**

When the vehicle speed reaches the preset speed, the device will identify the state of the driver's face and the driving state of the vehicle on the road through the camera and thus judge such events as fatigue and danger and then issue an in-cab alert to the driver and push an alarm notification to the platform .

5.3 Remote Management

- **Live video**

Through the background service you can use the device's cellular capability to transmit audio and video from the camera(s), so you can view the vehicle's status live.

- **History video**

Through the background service you can use the device's cellular capability to push the selected audio and video files as well as the history video files stored in the memory card to the platform.

- **Location query**

You can check the live or history locations of the vehicle via the platform to know its past trips.

5.4 Visual AI

- **ADAS**

The ADAS function is implemented via the front camera, which constantly monitor the road conditions. By judging the distance from the front vehicle and recognizing the lane marking, and based on the vehicle speed, it can detect near collisions and alert the driver to make the road safer and help protect drivers and other road users.

- **DMS**

By installing an optional DMS camera, your fleet's safety will be a level up. The DMS camera can detect high-risk driver behaviors such as fatigue (yawning/eye closure) and distraction (phone use/fiddling with stereo) and emit an audible alert to remind and coach driver in real-time.

- **Seatbelt Use Detection**

An inward-facing camera can help detect if the driver under monitoring has fastened its seatbelt. If not, it will emit an audible alert. This mechanism is very important in the event of accidents.

- **Facial Recognition (Face ID)**

An optional camera with facial recognition can help verify if the driver is a registered one by scanning its face and comparing the data with a face library, thus preventing unauthorized person to operate the vehicle.

6.1 FAQ

1. The device does not start and the LED indicators are off.

- (1) Check the ignition status of the vehicle, as the device will operate only when the vehicle is started;
- (2) Check if the device is securely connected to the B+, ACC, and GND wires of the vehicle;
- (3) Check if the fuse is blown or shorted.

2. The camera does not operate properly and the red indicator flashes.

- (1) Check if the memory card is inserted correctly;
- (2) Check the memory card on a computer to see if it is normal;
- (3) Check if the format of your memory card is FAT32. If not, please format it to FAT32.

3. The device cannot access the network and the blue indicator flashes.

- (1) Check if the SIM card is correctly attached and activated with the required mobile network services;
- (2) If it is an IoT card, you may need to configure the APN manually as the APN adaptation may fail.

4. The device cannot perform positioning and the green indicator flashes.

- (1) Drive your vehicle to an open area. The GNSS signals may be weak in an underground garage or a tunnel;
- (2) If the device is started under a high-rise building, it is a normal phenomenon that the signal search and positioning may be slow. In this case, you can drive your vehicle to an open area to speed up the positioning.

5. AI function (ADAS/DMS) fails to work.

- (1) The default speed for ADAS to activate is 60 km/h, and for DMS is 30 km/h. The corresponding AI function will only be activated when the speed of the vehicle exceeds the thresholds. You can also set your own threshold according to your needs.
- (2) Please check if the cameras are properly connected, if they are obstructed, or if the capture angles are appropriate.

6. The platform fails to receive some alerts.

- (1) Check if the switches for these alerts are enabled on the platform.

7. The camera becomes loose easily after adjusting the capture angle.

- (1) The angle of the camera can be adjusted to an optimal capture angle. Please make sure the screws at the camera-mount joint is tightened each time the capture angle is adjusted.

8. The mount base falls off easily after attachment.

- (1) The mount base is equipped with a 3M double-sided adhesive tape. Its adhesiveness may be affected if there is floating dust or grease on the install position. Therefore, please clean the install position before installing.

07 / After-sales Service Terms

7.1 Special Note

No prior notice will be given if the product is upgraded due to technological reasons. The appearance or color of the product is subject to the actual. The warranty card applies to the services of repair, replacement, and refund of the product with the following IMEI. Please keep this warranty card and the original receipt of purchase together in a safe place, as these will be needed at time of services.

7.2 Warranty Terms

For damages not caused by human factors, this warranty lasts for one year starting from the date of purchase. You can choose to pay for the repair services in any of the following cases:

- ① The warranty card is expired;
- ② No warranty card or valid proof of purchase;
- ③ The product, including its accessories, is not in the warranty period;
- ④ Damage caused by unauthorized repairs, crash, liquid spillage, incident, accident, modifications, or incorrect voltage input; or the label, IMEI, or counterfeit mark of the product is broken or scribbled;
- ⑤ Damages caused by installation or use not in accordance with the user manual;
- ⑥ Damage caused by force majeure such as fire, flood, or lightning;
- ⑦ The device model is inconsistent with that on the warranty card or the warranty card has been altered;
- ⑧ Other damages caused by force majeure.

No part of this document may be reproduced, retranslated, or copied in any form or by any means or for profit (electronic, photocopying, taping, etc.) without written permission of the Company.

7.3 Warning

This equipment has been tested and found to comply with the limits for a Class B digital device, pursuant to Part 15 of the FCC Rules. These limits are designed to provide reasonable protection against harmful interference in a residential installation. This equipment generates, uses and can radiate radio frequency energy and, if not installed and used in accordance with the instructions, may cause harmful interference to radio communications. However, there is no guarantee that interference will not occur in a particular installation.

If this equipment does cause harmful interference to radio or television reception, which can be determined by turning the equipment off and on, the user is encouraged to try to correct the interference by one or more of the following measures:

- Reorient or relocate the receiving antenna.
- Increase the separation between the equipment and receiver.
- Connect the equipment into an outlet on a circuit different from that to which the receiver is connected.
- Consult the dealer or an experienced radio/TV technician for help.

Disclaimer:

©All Rights Reserved Please read this manual carefully prior to use. No prior notice will be given for any changes made to the appearance, color, or accessories of the product.

This device complies with Part 15 of the FCC Rules. Operation is subject to the following two conditions: (1) this device may not cause harmful interference, and (2) this device must accept any interference received, including interference that may cause undesired operation.

Caution: Changes or modifications not expressly approved by the party responsible for compliance could void the user's authority to operate the equipment. This equipment complies with FCC radiation exposure limits set forth for an uncontrolled environment. This equipment should be installed and operated with minimum distance 20cm between the radiator and your body.

08 / Warranty Card

Customer Information:

Customer Name		IMEI No.	
Mailing Address			
Product Model		Phone	
Date of Purchase		Invoice No.	
Purchased From			
Address			
Phone			

Maintenance Record

Service Start Date	Problem and Solution	Service End Date	Customer Signature

Important

Please keep this warranty card in a safe place, as it is the proof for one-year free warranty services. If this card is lost, the Company will determine the date of purchase to be the thirtieth (30th) day after the date of production.